

STAINLESS WAFER BUTTERFLY VALVE - PN16

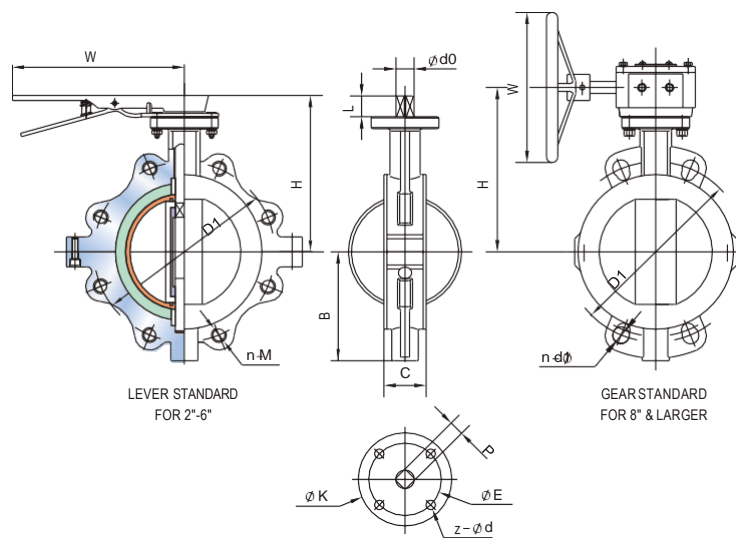

SPECIFICATIONS

- Wafer or Lugged type
- Manufactured to BS 5155
- Flanges to BS, DIN, ANSI
- Mounting Pad Flange to ISO5211
- Working Pressure: PN16



SIZE		C	B	W	H	L	d0	P	UPPER FLANGE				ANSI 150				DIN PN10/16		Weight (kg)		
in	DN								K	E	z-d	g	h	D1	n-d1	M	D1	n-d1	M	Wafer	Lug
1½	40	40	75	270	150	32	12.6	9	90	70	4-9	55	4	98.5	4-15	1/2"	110	4-18	M16	2.5	3.7
2	50	43	77	270	167	32	14.3	11	90	70	4-9	55	4	120.5	4-19	5/8"	125	4-18	M16	3.0	4.2
2½	65	46	91	270	170	32	14.3	11	90	70	4-9	55	4	139.5	4-19	5/8"	145	4-18	M16	3.0	4.2
3	80	46	95	270	170	32	14.3	11	90	70	4-9	55	4	152.5	4-19	5/8"	160	4-18	M16	3.5	4.5
4	100	52	121	270	181	32	15.7	11	90	70	4-9	55	4	190.5	8-19	5/8"	180	8-18	M16	4.8	7.8
5	125	56	125	270	205	32	18.9	14	90	70	4-9	55	4	216	8-22	3/4"	210	8-18	M16	6.8	10.8
6	150	56	150	270	219	32	18.9	14	90	70	4-9	55	4	241.5	8-22	3/4"	240	8-23	M20	8.0	13.8
8	200	60	182	360	268	32	22.1	17	125	102	4-12	70	4	298.5	8-22	3/4"	295	8-23	M20	24.8	32.5
10	250	68	226	300	284	45	28.4	22	125	102	4-12	70	4	362	12-25	7/8"	350/355	12-23/27	M20/M24	30.8	43.2
12	300	78	260	300	337	45	31.6	22	140	102	4-12	70	4	432	12-25	7/8"	400/410	12-23/27	M20/M24	44.0	55.0

MATERIALS OF

Item	Part Name	Material	
1	Body	WCB	CF8M
2	Stem	SS416	SS316
3	Seat	PTFE	PTFE
4	Disc	WCB+PTFE	CF8M+PTFE
5	O Disc	Viton	Viton